



Clifford & Snell

A division of Signature Ind. Ltd

OPERATING AND INSTALLATION INSTRUCTIONS FOR ATEX AND IECEx YO9 FLAMEPROOF AUDIBLE ALARMS

Tom Cribb Road, Thamesmead
London SE28 0BH
Tel: +44(0)20 8316 4477
or (0)20 8317 1717
Fax: +44(0)20 8317 2400
Email: cliffordandsnell@aol.com
www.cliffordandsnell.com

**ATEX
IECEx**

MAIN FEATURES

- High sound output 115dB for use in potentially explosive areas
- Light Weight Glass Reinforced Polyester Exd Enclosure
- Body manufactured in anti static, UV stable Glass Reinforced Polyester
- ATEX / IECEx Approved Gas & Dust. Zones 1 & 2
- Enclosure finished in Red High Performance Paint with ABS Flare Assembly
- 2 stage alarm, independently selectable second stage
- Dual 20mm gland entries. Unit supplied with one approved stopping plug and one dust cover
- Monitoring facility (DC only)
- Adjustable stainless steel ratchet bracket providing positive setting
- 32 selectable tones meeting international regulations
- Sound selection via 5 way DIL switch



DIMENSIONS mm

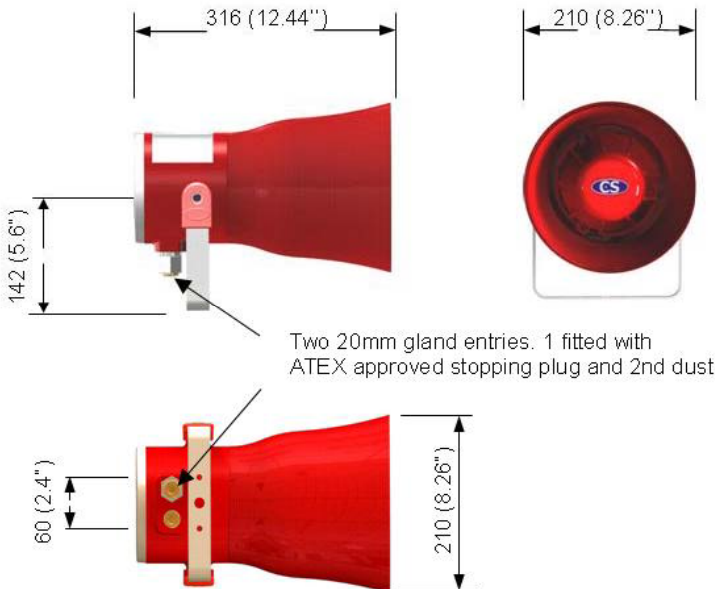

TECHNICAL SPECIFICATION

- IP 66 rated
- Weight 4.5 Kg
- Sound output 115dB(A) at 1 mtr
- Relative Humidity 95% @ 40 degC
- Certified Temperature Range -20 degC to +60 degC IIB and IIC
- Operating Voltage 24Vdc, 48Vdc, 115Vac / 230Vac
- Current consumption

24Vdc	600mA
48Vdc	300mA
115Vac	100mA
230Vac	55mA

For alarm type YO9, the chosen signal is selected via a DIL switch. The appropriate switch positions are detailed within the installation instructions.

MOUNTING

Stainless steel mounting bracket provided. Holes to suit M6, Pitch 60mm.



D8124 OPERATING AND INSTALLATION INSTRUCTIONS FOR standard Y09 YODALEX DIRECTIONAL FLAMEPROOF AUDIBLE ALARMS

THESE INSTRUCTIONS MUST BE READ AND UNDERSTOOD BEFORE CARRYING OUT ANY WORK ON THE ALARM.

Do not discard any packing material until installation is complete.

THESE ALARMS SHOULD ONLY BE INSTALLED BY A COMPETENT PERSONNEL

These alarms are certified in accordance with the ATEX Directive 94/9/EC. The certificate numbers and their associated marking are as follows:

Baseefa08ATEX0191X

CE₁₁₈₀  II 2 GD - Ex d IIB T6 (T_{amb} -20 °C to +60 °C)

Baseefa08ATEX0189X

CE₁₁₈₀  II 2 GD - Ex d IIC T6 (T_{amb} -20 °C to +60 °C)

These alarms are certified in accordance with the IEC60079-0:2004 Edition 4 and IEC60079-1:2003 Edition 5. The certificate numbers and their associated marking are as follows:

IEC Ex08.0062X

Exd IIB T6 ExtD A21 IP66 T_{amb} (-20 °C to +60 °C)

IEC Ex08.0061X

Exd IIC T6 ExtD A21 IP66 T_{amb} (-20 °C to +60 °C)

No alteration to the unit is allowed. In case the unit becomes faulty, It must be returned to the factory.

‘This equipment is designed and manufactured to protect against other hazards as defined in paragraph 1.2.7 of Annex II of the ATEX Directive 94/9/EC.

INSTALLATION AND OPERATING INSTRUCTIONS

These instructions apply to the following Alarm models:

Flameproof audible range, sounder type YO9 YA90BD, YA90BM, YA90BL, YA90BN
YA90CD, YA90CM, YA90CL, YA90CN

These products are a range of audible and visual alarms approved for use in potentially explosive atmospheres, and have been ATEX and IECEx certified by Baseefa using EN60079-0 and EN60079-1 and other relevant IEC standards.

Models are available for use in hazardous areas with the following classifications: Group IIB and IIC.

An alarm approved for use in a particular gas group may be used in areas where the gas group is of a lower hazard.

IIC equipment is suitable for Gas groups IIB and IIA, also

IIB equipment is suitable for Gas group IIA.

The alarms are suitable for outdoor use.

The Yodalex alarms meet the requirements of standards BS EN 60529: 1992, Degree of Protection IP66.

General

The alarms must be installed in accordance with these instructions.

The alarms must also be installed in accordance with local codes and/or special requirements of any authority having jurisdiction.

Models for connection to DC supplies have a DC lines status monitoring facility.

PREPARATION

ENSURE THE SUPPLY IS OFF BEFORE COMMENCING INSTALLATION.

A. Check that you have the correct alarm to satisfy the system specification.

Gas group and temperature?

Audible alarm?

Supply voltage?

Sound signal selected?

Suitable mounting location?

Cable connection and installation method?

B. Location

- Select a suitable location for the alarm with regard to the area to be covered by the sound signal.
- The surface should be flat in the area of the fixings and the material suitable to carry the weight of the alarm.
- The sound signal pattern is directional and the sounder should be mounted correctly.
- The cable must be connected to the alarm via a sealed component and this must be located adjacent to the cable entries in the alarm body.
- Suitable sealing devices are a sealed threaded nipple or a sealed gland; the choice of device depends upon the gas group applicable to the installation and on the chosen installation method.
- There are two entries to the alarm body and one or both may be used depending upon the number of cable cores required by the system arrangement.
- It is preferable that the cable and its seal be fitted at the factory or approved workshop; however the method for assembling the cable and sealed components is described below.

IMPORTANT

THE ALARM IS A PRECISION INSTRUMENT. TAKE EXTREME CARE WHEN HANDLING.

- Particular care is needed when removing or replacing components which form part of the flameproof enclosure.
- Exposed joint surfaces must be protected and not have contact with dust or dirt, or be knocked against any object.
- The end flanges must be fitted squarely and on no account is force to be used. The flange must not be hammered, levered with a metal instrument or the fixing screws used to pull down the flange.
- With care and patience, it will be found that the flange enters the body without difficulty.

Unscrew the six socket headed screws from the END CAP. (Socket head wrench 4 mm (5/32") across flats). These screws will not be fully tightened if the alarm is not a factory-sealed unit.

- Unplug the pressure unit cable from the PCB assembly.
- The exposed joints must be kept clean of dirt and not damaged in handling.
- Lay down the sounder assembly to one side on a clean piece of the packing material.

Cable connection

- Cable entry holes are provided to accommodate any suitable Ex certified flameproof cable entry device, thread adaptor or stopping plug certified as Equipment (not a Component).
- In order to maintain IP66 rating the thread needs to be sealed in accordance with IEC/EN 60079-14.
- Cable entry temperature may reach 70°C.
- The terminals accept wires of up to 2.5 mm².

SOUND SIGNAL SELECTION

- It is preferable if the sound signal selection is set at the factory or at an approved workshop.
- To make the sound signal selection, refer to the table of sound signals and the switch positions for the chosen sounds.
- Doubly check you have selected the correct switch positions for your chosen stage 1 alarm signal and for your chosen stage 2 alarm signal.
- Check again before re-assembly of the alarm.

RE-ASSEMBLY OF THE ALARM

- Reconnect the pressure unit cable connection; make sure this is secure.
- Make sure the PCB assembly is correctly located in the slides in the body. Re-assemble the sounder end cap to the main body but take care that the pressure unit wire is not trapped across the edge of the PCB assembly.
- Check that the 'O' ring is properly fitted in the groove in the body.
- Take care when fitting the end cap. This must be inserted squarely into the main body. Force must not be used, with patience it will be found that the end cap enters without difficulty.
- The screws must not be used to pull down the flange to the body.
- Each socket screw should be fitted with a lock washer, flat washer and an 'O' ring. The 'O' ring must locate in the groove at the base of the counter bore. Screw down the socket screws tightly.

Note:

- If the alarm has been in service and/or the socket headed screws in the flange have been previously tightened, it is advisable to replace the o-rings (Part No. GR0192) before retightening the screws.
- Ensure that the mounting surface at the installed location is flat and suitable for carrying the weight of the alarm.
- Remove the bracket, fixing screws and washers from the bag in the carton. Assemble the bracket to the alarm body enclosure using two off hexagon head set screws(M6 X 16 mm long), lock washers and flat washers.
- Check that the bracket is tightly secured to the alarm enclosure. The fixings for the alarm to the mounting surface are two holes $\varnothing 8.5$ mm (0.33 in) on 75 mm. (2.95 in) centres.
- Suitable bolts (not supplied) for securing should be used.

INTERCONNECTION OF ALARMS

Alarms may be connected in parallel, that is, up to ten alarms with common supplies may be connected as a single system loop. Both sets of terminals should be used to provide an 'in' and 'out' connection.

SYSTEM OPTIONS

Operating supply voltage	24Vdc/48Vdc/115Vac or 230Vac
Sound signal selections	32 (see table)
Alarm stages	Single or Two from all sounders
Cable cores	The number fitted depends upon the system requirements

EARTHING

- The alarm must be connected to a good quality earth.
- EARTHING points are provided both inside and outside the alarm enclosure. These EARTHING points are identified with the Ground Symbol.
- The internal earth connection must be used. The external terminal is for a supplementary bonding connection and is used where local code or authorities permit or require such connection.
- For certain connection options, the external earth terminal may have been removed.

MISCELLANEOUS DATA

- Weight (kg). {dc} 4.5 Kg {ac} 4.6 Kg
 - The sound-shaping components are of flame retardant ABS.
 - All external fasteners are of stainless steel.
 - All sounders have 32 sound signal selections. From the 32 sound signals, any signal may be chosen as the first stage alarm and any signal for the second stage alarm.
 - Sound output level and current consumption depends upon the signal selected.
- The given values apply for Gas Group IIB; for Gas Group IIB+H₂ or IIC, sound output is typically reduced by 3dB.

WARNING: POSSIBLE ELECTROSTATIC RISK

The Horn and associated parts may become electro-statically charged and should not be touched or rubbed when in operational service. If cleaning is required follow the warning given on the equipment label and clean only with a suitable damp cloth.

TORQUE SETTINGS

The following settings are for Stainless or HT Steel

- M5 – 3Nm

SOUND SIGNALS

<i>sound Signal</i>	<i>description</i>	<i>Freq.</i>	<i>rept. rate</i>	<i>sound switches 1 2 3 4 5</i>	<i>special applications</i>
				SW1, SW2	
1	Alternate two-tone	800-1000	0.5	1 1 1 1 1	Fire Alarms
2	Alternate two-tone	2500-3100	0.5	0 1 1 1 1	Security Alarms
3	Alternate fast two-tone	800-1000	0.25	1 0 1 1 1	Increased Urgency
4	Alternate fast two-tone	2500-3100	0.25	0 0 1 1 1	Security Deterrent
5	Alternate two-tone	440-554	0.4/0.1	1 1 0 1 1	Evacuation Alarm, FRANCE
6	Alternate two-tone	430-470	1.0	0 1 0 1 1	
7	Alternate v.fast two-tone	800-1000	0.13	1 0 0 1 1	
8	Alternate v.fast two-tone	2500-3200	0.07	0 0 0 1 1	
9	Alternate two-tone	440-554	2.0	1 1 1 0 1	Turn-out, SWEDEN
10	Continuous note	700	-	0 1 1 0 1	All Clear, SWEDEN
11	Continuous note	1000	-	1 0 1 0 1	
12	Continuous note	1000	-	0 0 1 0 1	
13	Continuous note	2300	-	1 1 0 0 1	
14	Continuous note	440	-	0 1 0 0 1	
15	Interrupted tone	1000	2.0	1 0 0 0 1	
16	Interrupted tone	420	1.25	0 0 0 0 1	
17	Interrupted tone	1000	0.5	1 1 1 1 0	
18	Interrupted tone	2500	0.25	0 1 1 1 0	
19	Interrupted tone	2500	0.5	1 0 1 1 0	
20	Interrupted tone	700	6/12	0 0 1 1 0	Pre-vital Message, SWEDEN
21	Interrupted tone	1000	1.0	1 1 0 1 0	
22	Interrupted tone	700	4.0	0 1 0 1 0	Air-raid Alarm, SWEDEN
23	Interrupted tone	700	0.25	1 0 0 1 0	Local Warning, SWEDEN
24	Interrupted tone	720	0.7/0.3	0 0 0 1 0	Industrial Alarm, GERMANY
25	Int,fast,rising volume	1400	0.25	1 1 1 0 0	
26	Fast siren	250-1200	0.085	0 1 1 0 0	
27	Rising constant,fall	1000	10/40/10	1 0 1 0 0	Industrial Alarm, GERMANY
28	ISO 8201 Evacuation	800-1000	as std	0 0 1 0 0	International Evacuation Alarm
29	Fast whoop	500-1000	0.15	1 1 0 0 0	
30	Slow whoop	500-1200	4.5	0 1 0 0 0	Evacuation Alarm, Netherlands
31	Reverse sweep	1200-500	1	1 0 0 0 0	Evacuation Alarm, GERMANY
32	Siren	500-1200	3.0	0 0 0 0 0	

switch settings: ON=1 and OFF=0

The PFEER sound signals recommended by UKOOA are:-

General Alarm	Sound Signal 15	Interrupted tone 1000 Hz
PAPA	Sound Signal 31	Reverse Sweep 1200-500 Hz
Toxic Gas	Sound Signal 11	Continuous Tone 1000 Hz

AC ALARM CONNECTION AND SOUND SIGNAL SELECTION

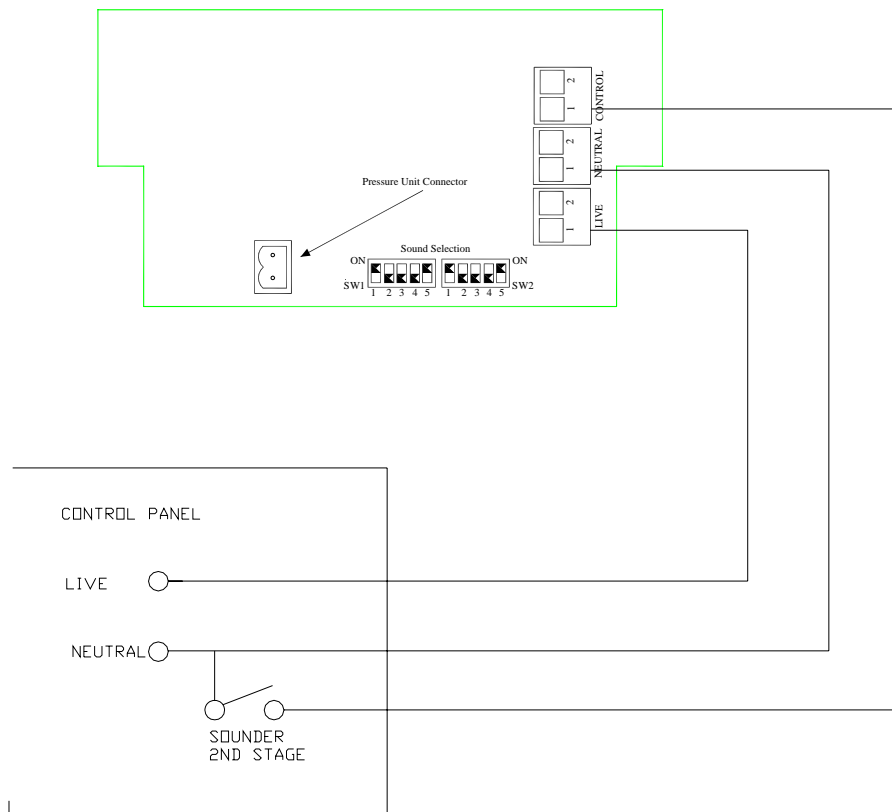

DC ALARM CONNECTION AND SOUND SIGNAL SELECTION

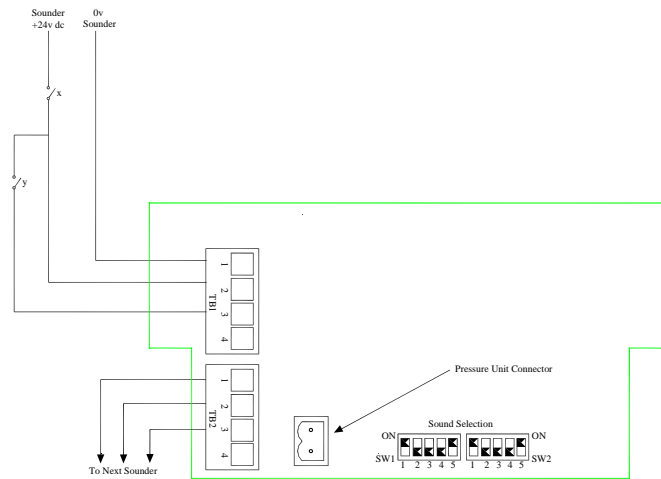

- A. Two stage alarm by third core
- Line monitoring by supply reversal
- Select alarm stage 1 on SW1
- Select alarm stage 2 on SW2

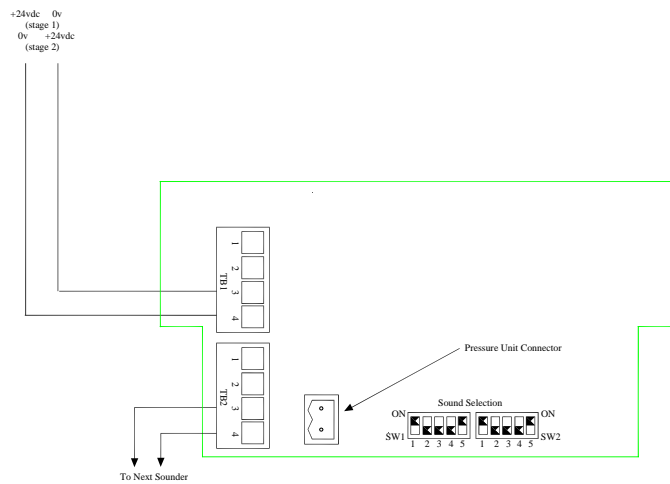

- B. Two stage alarm by Supply reversal
- Line monitoring by threshold method (<1V)
- Select alarm stage 1 on SW1
- Select alarm stage 2 on SW2
- Strobe operated from separate supply.

NOTE: That the two stage control always operates as follows:-

The first stage sounds by supplying volts to a unit via control switch 'x', This switch remains on and the second stage signal is controlled by switching volts to the third terminal via switch 'y'.