



Clifford & Snell

Wiring Diagrams

Tom Cribb Road, Thamesmead,
London SE28 0BH
Tel: +44 (0)20 8316 4477
or (0)20 8317 1717
Fax: +44 (0)20 8317 2400
Email: sales@cliffordandsnell.com
Web Site: www.cliffordandsnell.com

TYPICAL CONNECTION DIAGRAMS FOR YODALEX FLAMEPROOF AUDIBLE AND VISUAL ALARMS MODELS V6 - YO6 - YL6

For other options and full operating and installation instructions see website www.cliffordandsnell.com

STANDARD DC ALARM CONNECTION AND SOUND SIGNAL SELECTION

See Tone Table for switch settings

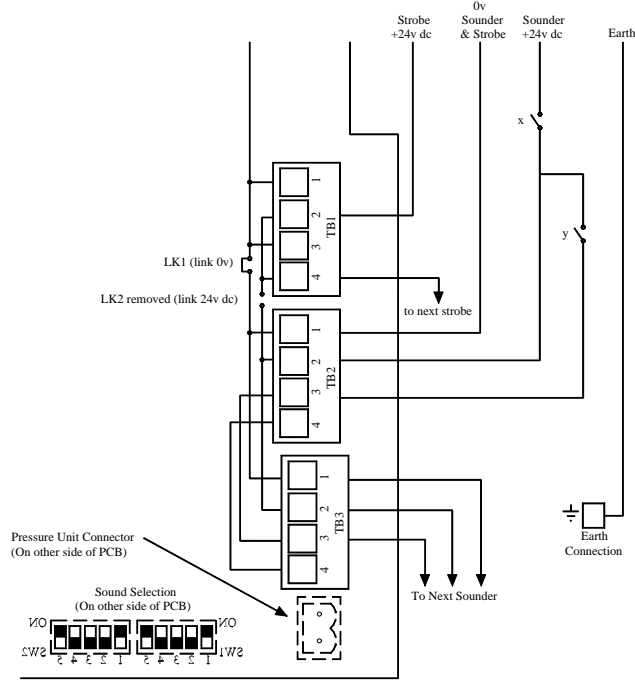

Two stage alarm by third core.
Strobe shown with common 0V.
Line monitoring by reversal.
Select alarm stage 1 on SW1.
Select alarm stage 2 on SW2.

NOTE: - The two stage control always operates as follows: -
The first stage sounds by supplying volts to a unit via control switch 'x'. This switch remains on and the second stage signal is controlled by switching volts to the third terminal via switch 'y'.

AC ALARM CONNECTION AND SOUND SIGNAL SELECTION

See Tone Table for switch settings

